

Safety Precautions

This manual is about the installation and operation of HT33 Series UPS (Hereinafter referred to as UPS).

Please carefully read this manual prior to installation.

The UPS must be debugged and maintained by the engineer commissioned by the manufacturer or the agent. Otherwise, human safety may be endangered and the damage of UPS shall not belong to the warranty scope.

UPS is only used for commercial / industrial purpose and cannot be used as power of life support equipment.



APPLICABLE STANDARDS

This product complies with CE 73/23 & 93/68 (low voltage safety) and 89/336 (EMC) , and EMC standards of Australia and New Zealand (C-Tick) , and the following UPS product standards:

*IEC62040-1-1-General and safety requirements for use in operator access area

*IEC/EN62040-2 EMC requirements CLASS C3

*IEC62040-3 Performance requirements and test methods

Continued compliance requires installation in accordance with these instructions and the use of manufacturer approved accessories only.



WARNING- High earth leakage current

Earth connection is critical before connecting the input supply (include both utility supply and battery) . This equipment must be earthed in accordance with local electrical authority codes of practice.

Earth leakage current exceeds 3.5 mA and is less than 1000 mA.

Transient and steady-state earth leakage currents, which may occur when starting the equipment, should be taken into account when selecting instantaneous RCCB or RCD devices.

Residual Current Circuit Breakers (RCCBs) must be selected insensitive to DC unidirectional pulses (class A) and transient current pulses (RCCBs) .

Note it that the earth leakage currents of the load will also flow across RCCB or RCD.



Components that can be maintained by user

All the equipment maintenance and servicing procedures involving internal access need special tools and should be carried out only by trained personnel. The components that can only be accessed by opening the protective cover with tools cannot be maintained by user.

This UPS full complies with "IEC62040-1-1-General and safety requirements for use in operator access area UPS". Dangerous voltages are present within the battery box. However, the risk of contact with these high voltages is minimized for non-service personnel. Since the component with dangerous voltage can only be touched by opening the protective cover with a tool, the possibility of touching high voltage component is minimized. No risk exists to any personnel when operating the equipment in the normal manner, following the recommended operating procedures in this manual.



Battery Voltage Higher Than 400Vdc

All the battery maintenance and servicing procedures involving internal access need special tools or keys and should be carried out only by trained personnel.

SPECIAL CARE SHOULD BE TAKEN WHEN WORKING WITH THE BATTERIES ASSOCIATED WITH THIS EQUIPMENT. WHEN CONNECTED TOGETHER, THE BATTERY TERMINAL VOLTAGE WILL EXCEED 400Vdc AND IS POTENTIALLY LEATHAL.

Battery manufacturers supply details of the necessary precautions to be observed when working on, or in the vicinity of, a large bank of battery cells. These precautions should be followed implicitly at all times. Particular attention should be paid to the recommendations concerning local environmental conditions and the provision of protective clothing, first aid and fire-fighting facilities.

CONTENTS

Chapter 1 Quick Start	6
1.1 Introduction	6
1.2 Initial Checking	6
1.3 Environment Checking	6
1.4 Installation Checking	6
Chapter 2 Installation Guidance	7
2.1 Introduction	7
2.2 Select Installation Position	7
2.2.1 Distribution Room	7
2.2.2 Battery Room	8
2.2.3 Storing	8
2.3 Disassembly, Initial Checking and Positioning	8
2.3.1 System Packing	8
2.3.2 UPS Composition	9
2.3.3 Operation Space	10
2.3.4 Front and Back Access	10
2.3.5 Final Positioning	10
2.3.6 Cable Entry	10
2.4 Protective Devices	10
2.4.1 Rectifier and Bypass Input Supply of the UPS	11
2.4.2 Battery	11
2.4.3 UPS Output	11
2.5 Power Cables	12
2.5.1 Maximum stable state current and configuration of cable system	12
2.5.2 Cable Connection	12
2.6 Control and Communication Cabling	13
2.6.1 Dry Contact Interface of Battery and Environmental Temperature Detection	13
2.6.2 Remote EPO Input Port	14
2.6.3 Generator Input Dry Contact	15
2.6.4 BCB Interface	15
2.6.5 Battery Warning Output Dry Contact Interface	16
2.6.6 Integrated Warning Output Dry Contact Interface	16
2.6.7 Mains Failure Warning Output Dry Contact Interface	17
2.6.8 RS232 Port and SNMP Card Port	17
2.7 Installation Diagram	18
Chapter 3 Operations	20
3.1 Introduction	20
3.1.1 Principle	20
3.1.2 Bypass Module	21
3.1.3 Battery Temperature Compensation	21
3.2 Operation Mode	21
3.2.1 Normal Mode	22
3.2.2 Battery Mode	22

3.2.3 Auto-Restart Mode.....	22
3.2.4 Bypass Mode.....	22
3.2.5 Maintenance Mode.....	22
3.2.6 ECO Mode	22
3.2.7 Frequency Converters Mode	23
3.2.8 Parallel connection redundancy mode	23
3.3 Battery Management	23
3.3.1 Normal Function	23
3.3.2 Advanced Functions (Battery Self-checking and Maintenance).....	23
3.4 Battery Protection.....	24
Chapter 4 Installation of Parallel Operation	
System	25
Chapter 5 Operating Procedures.....	
27	
5.1 Power Switches	27
5.2 UPS Start-up.....	27
5.2.1 Normal Mode Start.....	27
5.2.2 Battery Module Start (Only Applicable for UPS with Battery Cold Start Elements)	29
5.3 Procedure for Switching between Operation Modes	29
5.3.1 Procedure for Switching the UPS into Battery from Normal Mode	29
5.3.2 Procedure for Switching the UPS into Bypass from Normal Mode	29
5.3.3 Procedure for Switching the UPS into Normal from Bypass Mode	31
5.3.4 Procedure for Switching the UPS into a Maintenance Bypass from Normal Mode	31
5.3.5 Procedure for Switching the UPS into Normal from a Maintenance Bypass Mode	31
5.4 Procedure for Completely Powering down a UPS.....	31
5.5 EPO Procedure	32
5.6 Language Selection	32
5.7 Control Password	32
Chapter 6 Operator Control and Display	
Panel.....	33
6.1 Introduction.....	33
6.1.1 LED Indicator	34
6.1.2 Audible Alarm (buzzer)	34
6.1.3 Functional Keys	34
6.2 LCD Display Type	35
6.2.1 Default Display	36
6.2.2 System information window	36
6.3 Alarm List	38
Chapter 7 Maintenance	
40	
7.1 Instruction of Maintenance Operation.....	40
7.1.1 Precautions.....	40
7.1.2 Instruction to Bypass Module	40
7.2 Replacement of dust screen (optional)	40
Chapter 8 Product Specification	
42	
8.1 Applicable Standards.....	42

8.2 Environmental Characteristics.....	42
8.3 Mechanical Characteristics.....	42
8.4 Electrical Characteristics (Input Rectifier)	42
8.5 Electrical Characteristics (Intermediate DC Link).....	43
8.6 Electrical Characteristics (Inverter Output).....	43
8.7 Electrical Characteristics(Bypass Mains Input).....	44
8.8 Efficiency	45

Chapter 1 Quick Start

1.1 Introduction

This chapter introduces the basic principles for UPS installation and debugging, so that customers can install and debug UPS quickly.

1.2 Initial Checking

Perform the following checking operations prior to the UPS installation.

1. Visually examine if there is any damp, water, or damage inside and outside the UPS packing, products and battery equipments due to the transportation. Report any such damage to the shipper immediately.
 2. Verify the product label and confirm the correctness of the equipment. The equipment label is attached on the back of front door. The UPS model, capacity and main parameters are marked on the label.
 3. Verify correctness of the accessories. If there is any mistakes for accessories, contact with shipper or provider.

1.3 Environment Checking

Before installing UPS, please check these items as below:

1. Is the UPS operation environment temperature above 25°C? If so, please add cooling equipments.
Note: Environment temperature above 20°C, battery life will reduce to half when environment rise each 10°C
2. Is the UPS operation environment temperature below 0°C? If so, please add heaters.
3. Is the UPS operation environment humidity is above 90%? Is there any condensing? If so, please add additional protection.
4. In the UPS operation environment, is there any sunshine shining in directly or life-form coming in? If so, please add additional protection.
5. In the UPS operation environment, is there any dust, combustible or explosive gas? If so, please add additional protection.

1.4 Installation Checking

After finishing installation, please check these items as below:

1. Is UPS installed on the flame-retardant materials?
2. Are all cables connected exactly?
3. Are all grounded system connected according to the manual?
4. Is there enough operation space around UPS?
5. Please confirm all UPS external terminals are fastened, the moment should meet requirements.
6. Please confirm that there are no screws, cables and other conductor left in the UPS. If there is, please take out.

Chapter 2 Installation Guidance

2.1 Introduction

This chapter introduces UPS installation, it provide normal installation steps and ideas. Please installation engineers operate according to difference for each place,



Warning-Installation can only be done by authorized engineers

1. Do not apply electrical power to the UPS equipment before the approval of commissioning engineer.
2. The UPS should be installed by a qualified engineer in accordance with the information contained in this chapter.



Note: 3-Phase 4-Wire Input Power is required

The standard UPS can be connected to TN, TT and IT AC distribution system (IEC60364-3) of 3-phase 5-wire



WARNING: battery hazards

SPECIAL CARE SHOULD BE TAKEN WHEN WORKING WITH THE BATTERIES ASSOCIATED WITH THIS EQUIPMENT. When connecting the battery, the battery terminal voltage will exceed 400Vdc and is potentially lethal.

- Eye protection should be worn to prevent injury from accidental electrical arcs.
- Remove rings, watches and all metal objects.
- Only use tools with insulated handles.
- Wear rubber gloves.
- If a battery leaks electrolyte, or is otherwise physically damaged, it must be replaced, stored in a container resistant to sulfuric acid and disposed of in accordance with local regulations.
- If electrolyte comes into contact with the skin, the affected area should be washed immediately with water.

2.2 Select Installation Position

2.2.1 Distribution Room

The UPS is designed for indoor installation, which shall be located in a clean environment with adequate ventilation to keep the environmental temperature within the required specification. The UPS uses forced convection cooling by internal fans. Cooling air enters the module through ventilation grills located at the front part of the cabinet and exhausted through grills located in the rear part of the cabinet. Please do not block the ventilation holes.

If necessary, a system of extractor fans should be installed to aid cooling-air flow. An air filter should be used when the UPS is to operate in a dirty environment and should be regularly cleaned to maintain airflow.

Note: The UPS should be installed on a cement surface or other surface that is not combustible.

2.2.2 Battery Room

The battery will generate some amount of hydrogen and oxygen at the end of charging, so the fresh air volume of the battery installation environment must meet EN50272-2001 requirements. The ambient temperature of the battery must be stable. Ambient temperature is a major factor in determining the battery capacity and life. The nominal operating temperature of battery is 20°C. Operating above this temperature will reduce the battery life, and operation below this temperature will reduce the battery capacity. If the average operating temperature of battery is increased from 20°C to 30°C, then the service life of the battery will be reduced by 50%. If the operating temperature of the battery is above 40°C, then the battery service life will be decreased in exponent rate. In a normal installation, the battery temperature is maintained between 15°C and 25°C. Keep batteries away from heat sources or air outlets.

If external batteries are to be used, a battery protection device (a DC circuit breaker) must be mounted as close as possible to the batteries, and the connecting cables should be as short as possible.

2.2.3 Storing

If the equipment not be installed immediately, it must be stored in a room so as to protect it against excessive humidity and heat sources. The battery needs to be stored in dry and cool place with good ventilation. The most suitable storage temperature is 20 °C to 25°C.

2.3 Disassembly, Initial Checking and Positioning

Check the packaging first upon the arrival of product to see if there is any damage; open the packaging to check the equipment; report any such damage to the shipper immediately.

2.3.1 System Packing

Open the wooden case first, then take out the foam. Be careful not to scratch the product.

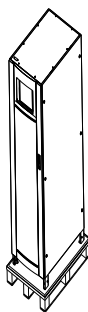

Fig 2-1 UPS Packing Diagram

Tip: Dismantle the bolts that connect the cabinet and wooden pallet after disassembly, then lift the cabinet to installation position. The dismantlement should be careful so as not to scratch the body.

Verify the product label and confirm the correctness of the equipment. The equipment label is attached on the back of front door. The UPS model, capacity and main parameters are marked on the label.

Warm Tips: Please dispose the wasted materials in accordance with environmental

protection requirements after disassembly.

To prolong the service life, the place chosen for the UPS must guarantee:

- Easy wiring
- Sufficient space for operation
- Air sufficient enough to dispel heat produced by UPS
 - Against ambient corrosive gases
 - Against excessive humidity and heat sources
 - Against dust
- With the current fire prevention requirements
 - The operating environment temperature is within 20°C-25°C. The batteries are at maximum efficiency in this temperature range (for information about the battery storage and transportation as well as the environment, please refer to table 8-2)

2.3.2 UPS Composition

UPS composition shall refer to fig 2-2.

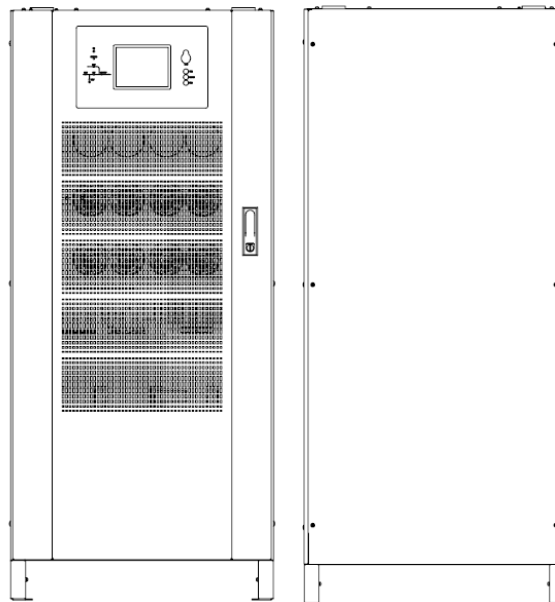

a. 40KVA~80KVA cabinet

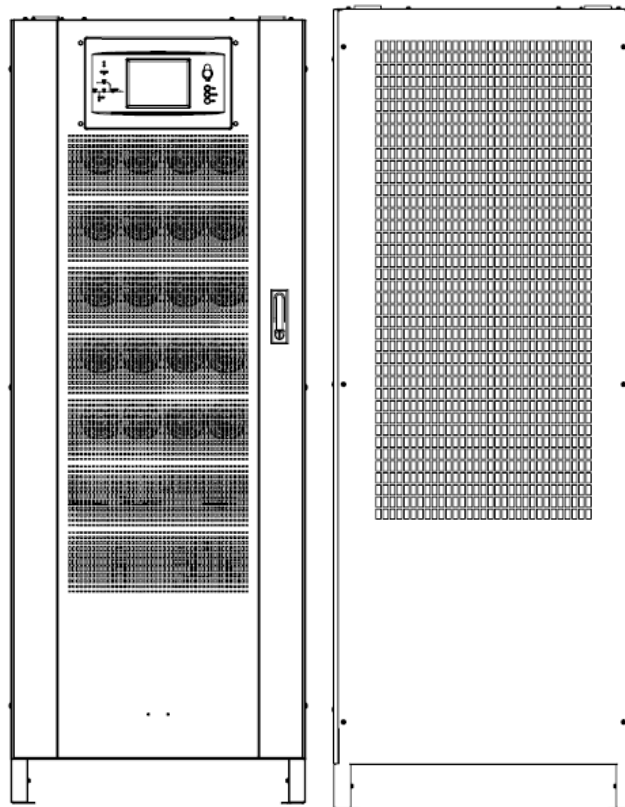

b.100KVA~120KVA cabinet with built-in battery

Fig 2-2 UPS Composition Diagram

2.3.3 Operation Space

As UPS has no ventilation grills at either side, no clearances are required for the sides.

To enable routine tightening of power terminations within the cabinet, it is recommended that clearance around the front and back of the equipment should be sufficient to enable free passage of personnel with the doors fully opened. The back door of the cabinet is more than 800mm from the wall or other cabinets.

2.3.4 Front and Back Access

The component layout of the UPS supports front and back access for servicing, diagnosing and repairing the UPS, thus reducing the space requirement for side access.

2.3.5 Final Positioning

When the equipment has been finally positioned, ensure the adjustable feet are set so that the UPS will remain stationary and stable.

2.3.6 Cable Entry

Low incoming line and upper incoming line is used for 40KVA~120KVA UPS, and a line incoming hole is respectively provided on the bottom and top of UPS.

2.4 Protective Devices

For safety concerns, it is recommended to install external circuit breakers or other protective devices

for the input AC supply of the UPS system. This section provides generic practical information for qualified installation engineers. The installation engineers should have the knowledge of the regulatory wiring standards, and of the equipment to be installed.

2.4.1 Rectifier and Bypass Input Supply of the UPS

Install suitable protective devices in the distribution unit of the incoming mains supply, considering the power cable current-carrying capacity and overload capacity of the system (see Table 1). Generally, the magnetic circuit breaker with IEC60947-2 tripping curve C (normal) at the 125% of the current listed in table 2-1 is recommended.

 Note
For IT power network system, 4-pole protective device must be installed on the external input distribution of the UPS.

Earth leakage current

If protection against earth faults (RCD devices) is required for the upstream of the input supply, the installed device should:

- Sensitive to DC unidirectional pulses (class A) in the network
- Insensitive to transient current pulses
- Have an average sensitivity that is adjustable between 0.3A-1A

The RCCB must be sensitive to DC unidirectional pulses (class A) in the network, while insensitive to transient current pulses, as shown in fig 2-3 respectively.

Fig 2-3 RCCB sign

2.4.2 Battery

A battery unit is composed of 40 batteries connected in series, a centreline is drawn from in between (the joint part between the 20th and 21st battery), plus the line drawn from the front and back, there are altogether 3 lines connected with UPS line contact bank. The battery line must push through a DC circuit breaker before connecting to corresponding UPS line contact bank. The detailed wiring please refers to fig 2-4 below:

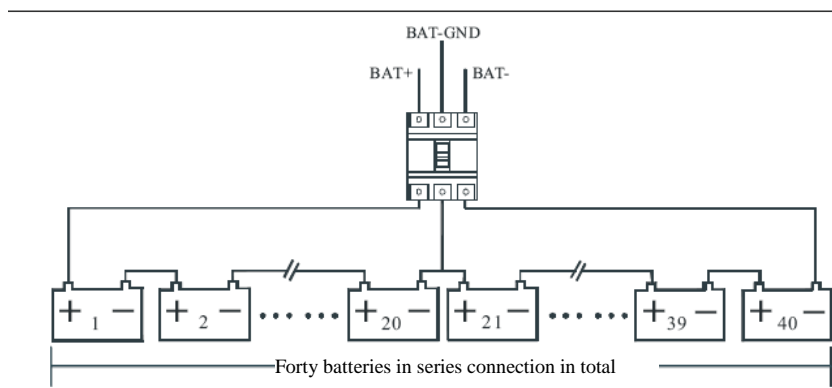

Fig 2-4 Diagram of batteries connected in series

2.4.3 UPS Output

A main output switch has been installed in UPS; the user shall install the overcurrent protective

device on the bypass of each output of the external distribution cabinet.

2.5 Power Cables

Design the cables according to the descriptions in this section and local regulatory wiring standards, and the environmental conditions should be taken into consideration. Refer to IEC60950-1 table 3B.

 Warning
<p>Prior to cabling the UPS, confirm the status and positions of the switches of the UPS rectifier input power supply / bypass power supply and mains power distribution board.</p> <p>Ensure that these switches are opened and attached with WARNING label so as to prevent unauthorized operation to these switches.</p>

2.5.1 Maximum stable state current and configuration of cable system

Table 2-1 Maximum stable state current and configuration of cable system

System Name	Items	HT	HT	HT	HT	HT	HT
		33040	33050	33060	33080	33100	33120
Capacity	System capacity	40k VA	50k VA	60k VA	80k VA	100k VA	120k VA
	Cabinet dimension (mm) W*D*H	600*850*1350				600*850*1700	
Main Input	Rated current A	60	75	90	120	150	180
	Cable mm ²	16	25	25	35	50	50
Output	Rated current A	60	75	90	120	150	180
	Cable mm ²	16	25	25	35	50	50
Battery	Rated current A	71	88	106	142	178	212
	Cable mm ²	25	25	35	50	50	75
PE	Cable mm ²	35	35	35	35	50	50

 Warning
<p>FAILURE TO FOLLOW ADEQUATE EARTHING PROCEDURES CAN RESULT IN EMI, ELECTRIC SHOCK HAZARD OR RISK OF FIRE, SHOULD AN EARTH FAULT OCCUR..</p>

2.5.2 Cable Connection

 Important
<p>The operations described in this section must be performed by authorized electricians or qualified technical personnel.. If you have any difficulties, do not hesitate to contact our Customer Service & Support department .</p>

After the equipment has been finally positioned and secured, connect the power cables as described in the following procedures:

1. Verify that all the external input distribution switches of the UPS are completely opened and the UPS internal maintenance bypass switch is opened. Attach necessary warning signs to these switches to prevent unauthorized operation.
2. Open the back door of the cabinet, remove the cover and then the input and output terminal, battery terminal and earth terminal are visible.
3. Connect the input earth wire to input earth terminal. Please note: the earth wire shall

be connected in accordance with related local or state regulation

4. If in UPS, same electric supply input is used for the by-pass and rectification, AC input cables should be connected with the input terminal of UPS (Main input A-B-C-N) and the output load cables are connected with the output terminal of UPS (Output A-B-C-N). If in UPS, two electric supply inputs are respectively used for the by-pass and rectification, the AC input cables should be respectively connected with the main input terminal of UPS (Main input A-B-C-N) and the input terminal of the bypass, and at the same time the short circuit copper bars of the main circuit and the bypass are removed; fastening moment of force is 30kg(M5), 50kg(M6), 180kg(M8) and 260kg(M10). Attention is given to phase sequence and the short circuit at a joint between cable terminals.

5. Connect the battery cables between the UPS battery terminals and battery switch.
ENSURE CORRECT PHASE ROTATION.



Warning-Hazardous battery terminal voltage of 400Vdc

Ensure the correct polarity connection between the battery terminals and the UPS terminals: Positive terminal to positive terminal, negative terminal to negative terminal, and disconnect one or more than one cable between every two layers of batteries. Do not connect the cables and close the battery circuit breakers before getting the approval from the commissioning engineer.

6. Re-install all the protective covers.

2.6 Control and Communication Cabling

As shown fig. 2-5, the dry contact interface (J2-J10), communication interface (RS232 interface, 485 interface and SNMP card interface) and LBS interface.

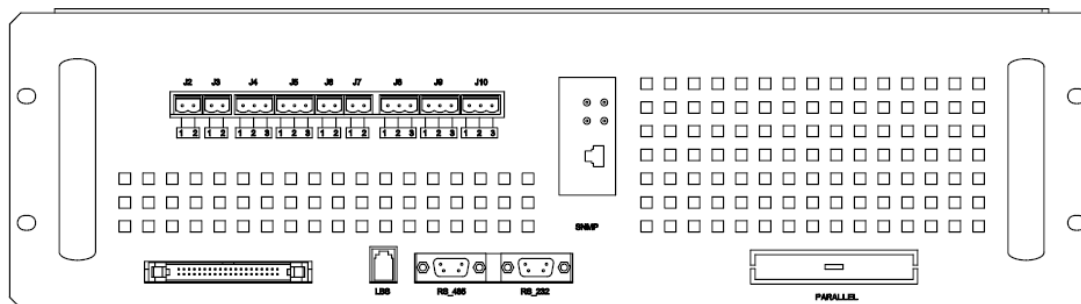

Fig 2-5 Dry contact interface and communication interface

The UPS accepts external signal from zero-voltage (dry) contacts connected through external dry contact terminals produced and phoenix terminals that are in bypass module. Through software programming, these signals become active when these contacts connect to +24V to ground. The cables connected to DRY terminal must be separated from power cables. Moreover, these cables should be double insulated with a typical 0.5 to 1.5 mm² cross-section area for a maximum connection length between 25 and 50 meters.

2.6.1 Dry Contact Interface of Battery and Environmental Temperature Detection

The input dry contact J2 and J3 can detect the temperature of batteries and environment respectively, which can be used in environment monitoring and battery temperature compensation 1.

J2 and J3 interfaces diagram are shown in fig 2-6, the description of interface is in table 2-2

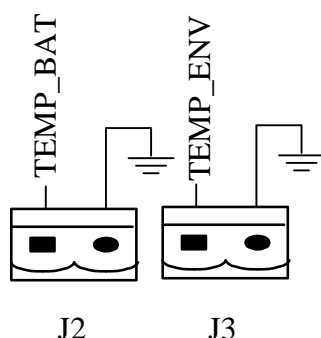

Fig 2-6 Diagram of J2 and J3 dry contact for temperature detecting

Table 2-2 Description of input dry contact interface J2 and J3

Position	Name	Purpose
J2.1	TEMP_BAT	Battery temperature detection
J2.2	GND	Power ground
J3.1	TEMP_ENV	Environment temperature detection
J3.2	GND	Power ground

Note:
Specified temperature sensor is required for temperature detection (R25=50hm, B25/50=3275), please confirm with the manufacturer, or contact local maintenance engineers when placing an order.

2.6.2 Remote EPO Input Port

The UPS has an Emergency Power OFF (EPO) function. This function can be activated by pressing a button on the control panel of the UPS or through a remote contact provided by the user. The EPO pushbutton is protected by a hinged plastic cover.

J4 is the input port for remote EPO. It requires shorting NC and +24v during normal operation, and the EPO is triggered when opening NC and +24v, or shorting NO and +24v. The port diagram is shown in Fig 2-7, and port description is shown in table 2-3.

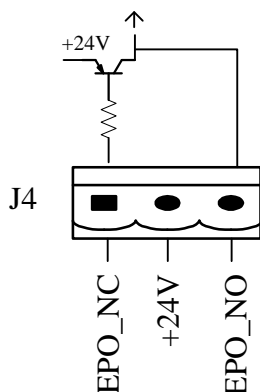

Fig 2-7 Diagram of input port for remote EPO

Table 2-3 Description of input port for remote EPO

Position	Name	Purpose
J4.1	EPO_NC	EPO is activated when disconnecting from J4.2
J4.2	+24V	+24V, connect the common terminal of NC and NO
J4.3	EPO_NO	EPO is activated when shorting with J4.2

The EPO is triggered when shorting pin 2 and 3 or opening pin 2 and 1 of J4.

If an external emergency stop facility is required, it is connected via the reserved terminals of J10. The external emergency stop facility needs to use shielded cables to connect to the normally

open/closed remote stop switch between these two pins. If this facility is not used, then pin 3 and pin 4 of J4 must be open, or pin 1 and pin 2 of J4 must be shorted.

Note
<ol style="list-style-type: none"> 1. The emergency stop action within the UPS will shut down the rectifier, inverter and static bypass. However, it does not internally disconnect the mains input power supply. To disconnect ALL power to the UPS, open the upstream input circuit breaker(s) when the EPO is activated. 2. Pin 1 and 2 of J4 have been shorted before the UPS is delivered

2.6.3 Generator Input Dry Contact

J5 is status interface for generator connection. Connect pin 2 of J5 with + 24V power supply, and it indicates that the generator has been connected with the system. The interface diagram is shown in fig 2-8 and interface description is shown in table 2-4

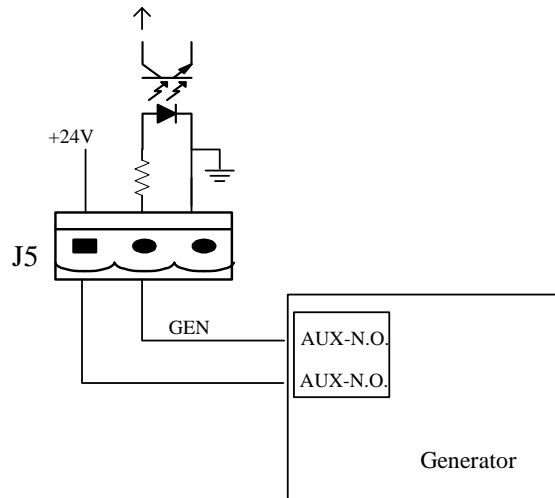

Fig 2-8 Diagram of status interface and connection of generator

Table 2-4 Description of maintenance bypass switch and output switch status interface

Position	Name	Purpose
J5.1	+24V	+24V power supply
J5.2	GEN	Connection status of generator
J5.3	GND	Power ground

2.6.4 BCB Interface

J6 and J7 are battery circuit breaker (BCB) interface. The interface diagram is shown in fig 2-9 and interface description is shown in table 2-5.

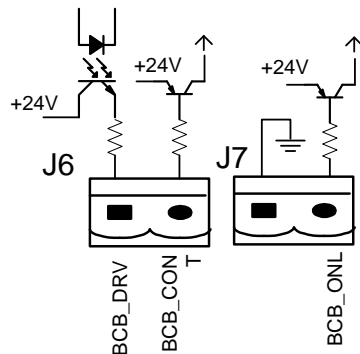

Fig 2-9 BCB Interface

Table 2-5 Description of BCB Interface

位置	名称	描述
J6.1	BCB_DRV	BCB drive signal: providing +24V, 20mA drive signal
J6.2	BCB_CONT	BCB contact status, connect to BCB's normal open signal
J7.1	GND	Power ground
J7.2	BCB_ONL	BCB online input (normal open), it shows BCB is online when this signal connects to GND.

2.6.5 Battery Warning Output Dry Contact Interface

J8 is the output dry contact interface, which outputs the battery warnings of low or excessive voltage, when the battery voltage is lower than set value, an auxiliary dry contact signal will be provided via the isolation of a relay. The interface diagram is shown in fig 2-10, and description is shown in table 2-6.

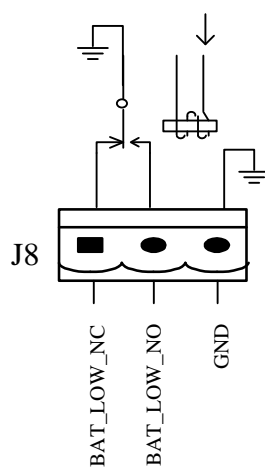

Fig 2-10 Battery warning dry contact interface diagram

Table 2-6 Battery warning dry contact interface description

Position	Name	Purpose
J8.1	BAT_LOW_NC	Battery warning relay (normally closed) will be open during warning
J8.2	BAT_LOW_NO	Battery warning relay (normally open) will be closed during warning
J8.3	GND	Center of battery warning relay

2.6.6 Integrated Warning Output Dry Contact Interface

J9 is the integrated warning output dry contact interface, when one or more than one present warning is triggered, the system will send integrated warning information, and provide an auxiliary dry contact signal via the isolation of a relay. The interface diagram is shown in fig 2-11, and description is shown in table 2-7

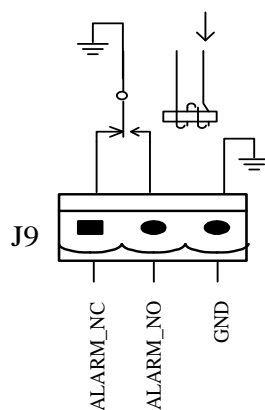

Fig 2-11 Integrated warning dry contact interface diagram

Table 2-7 Integrated warning dry contact interface description

Position	Name	Purpose
J9.1	ALARM_NC	Integrated warning relay (normally closed) will be open during warning
J9.2	ALARM_NO	Integrated warning relay (normally open) will be closed during warning
J9.3	GND	Centre of integrated warning relay

2.6.7 Mains Failure Warning Output Dry Contact Interface

J10 is the output dry contact interface for mains failure warning, when the mains fails, the system will send a mains failure warning information, and provide an auxiliary dry contact signal via the isolation of a relay. The interface diagram is shown in fig 2-12, and description is shown in table 2-8.

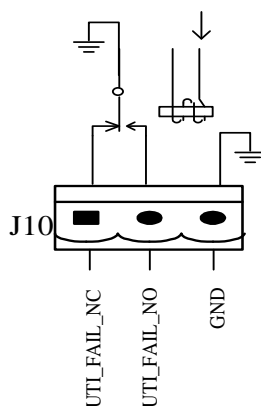

Fig 2-12 Mains failure warning dry contact interface diagram

Table 2-8 Mains failure warning dry contact interface description

Position	Name	Purpose
J10.1	UTI_FAIL_NC	Mains failure warning relay(normally closed) will be open during warning
J10.2	UTI_FAIL_NO	Mains failure warning relay normally open) will be closed during warning
J10.3	GND	Centre of mains failure warning relay

2.6.8 RS232 Port and SNMP Card Port

RS232 and RS485 Port: provide serial data which can be used for commissioning and maintenance by authorized engineers or maintainers, or can be used for networking or integrated monitoring system in the service room.

SNMP Card Port: used for field installation of the communication option card (SNMP card).

2.7 Installation Diagram

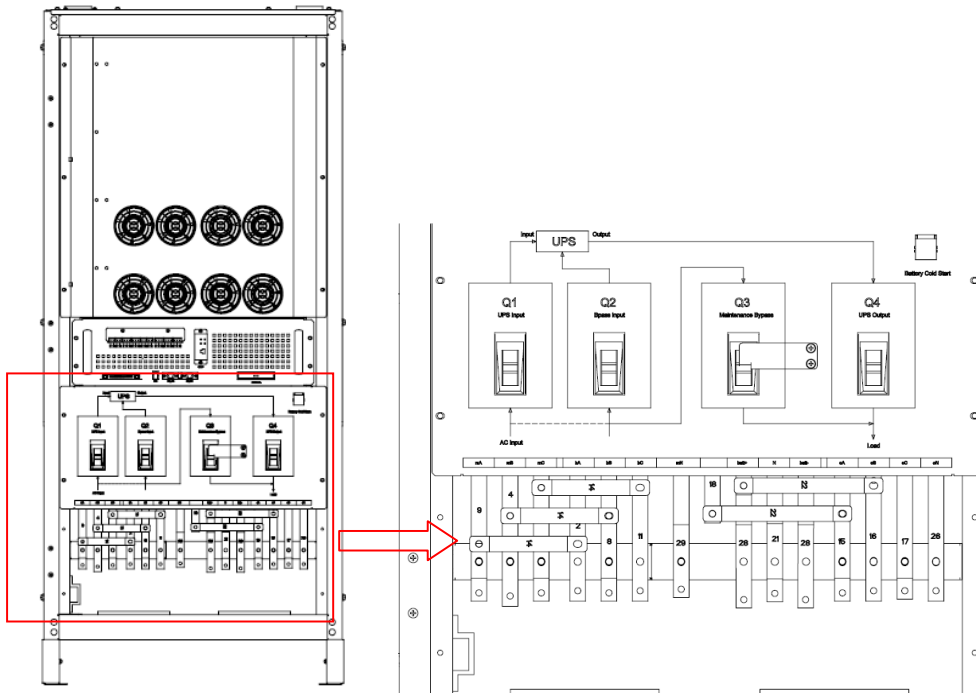
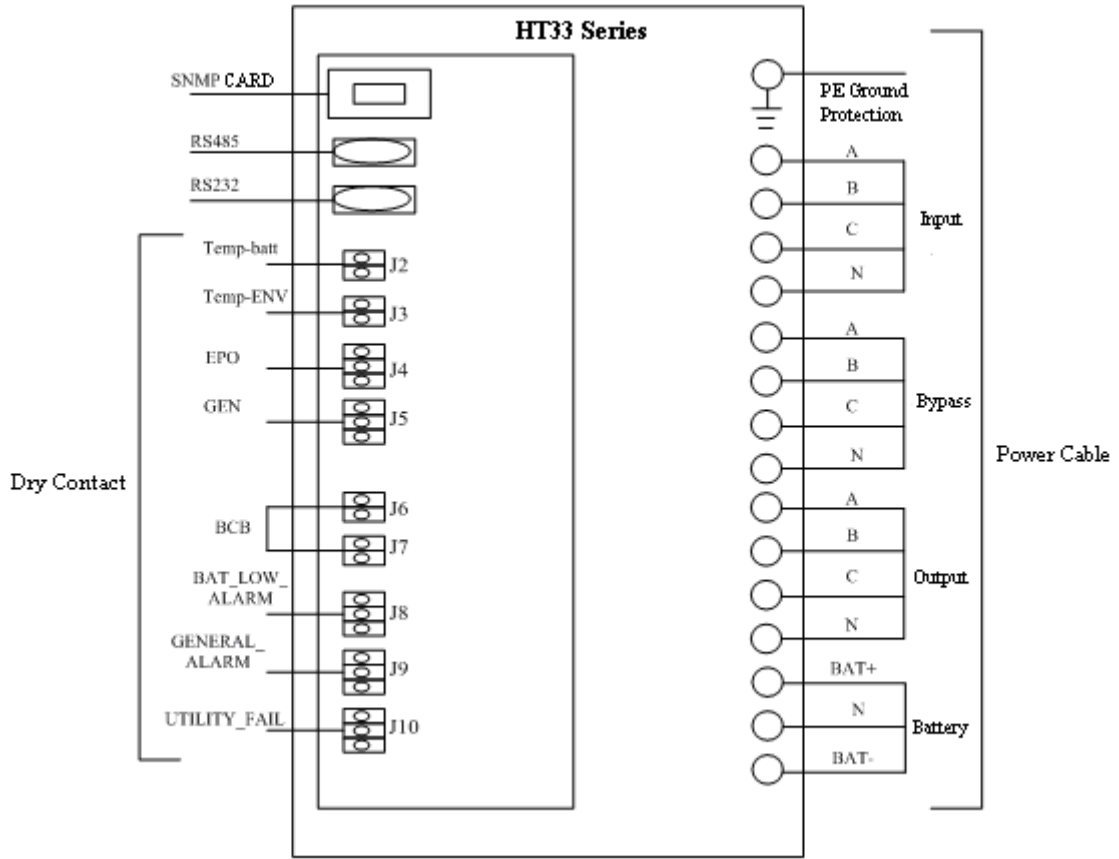

a. 40KVA~80KVA wiring diagram

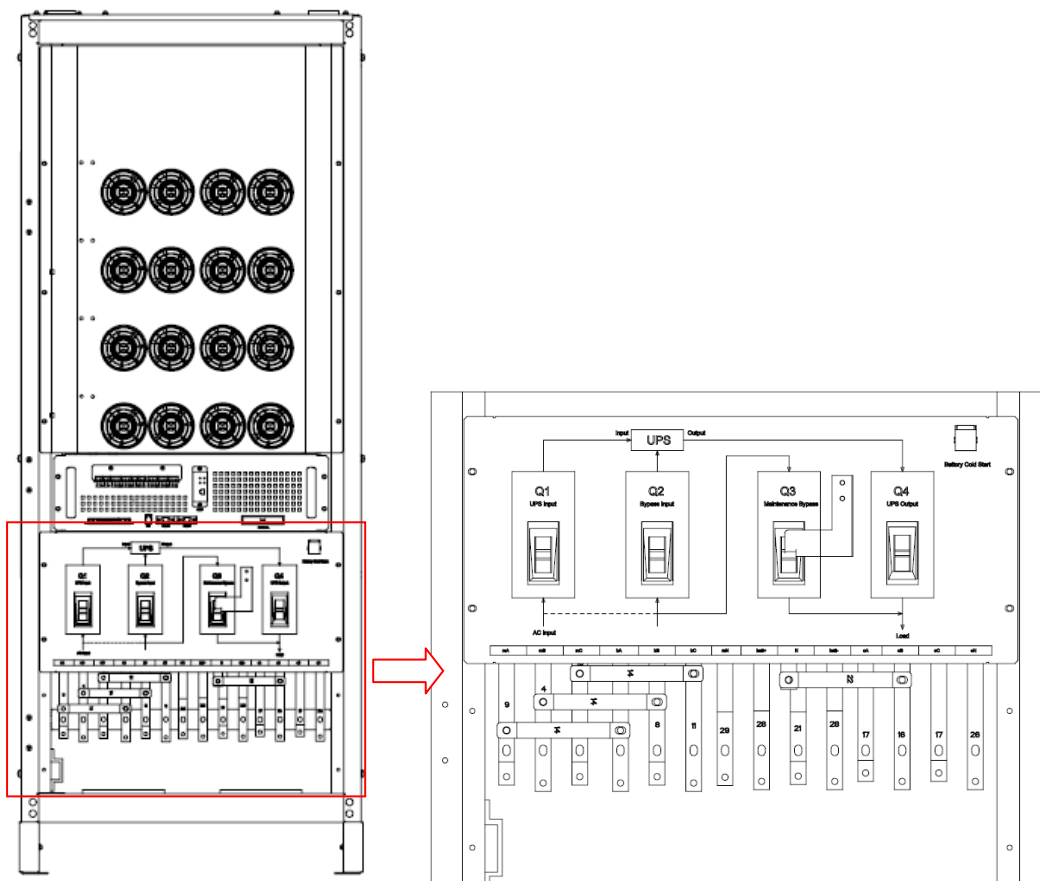

b. 100KVA~120KVA wiring diagram
Fig 2-13 40~120KVA UPS wiring diagram

Chapter 3 Operations

This chapter introduces the basic knowledge of UPS operations, including working principle, operation mode, battery management and protection.



Warning: Hazardous mains voltage and/or battery voltage present(s) behind the protective cover

1. The components that can only be accessed by opening the protective cover with tools cannot be operated by user.
2. Only qualified service personnel are authorized to remove such covers.

3.1 Introduction

UPS provides high quality uninterruptible AC power to your critical load. The power from UPS is free from voltage and frequency variations and disturbances (interruption and spike) experienced at the Mains AC input supply.

This is achieved through high frequency double conversion power pulse width modulation (PWM) associated with full digital signal processing control (DSP), which features high reliability and convenience for use.

3.1.1 Principle

As shown in fig 3-1, the AC input mains source is supplied at UPS input and converted into a DC source. This DC source feeds the Inverter that converts the DC source into a clean and input independent AC source. The battery powers the load through the inverter in case of an AC input mains power failure. The utility source can also power the load through the static bypass.

When the UPS needs maintenance or repair, the load can be transferred to maintenance bypass without interruption and the power module and bypass module can be removed for maintenance.

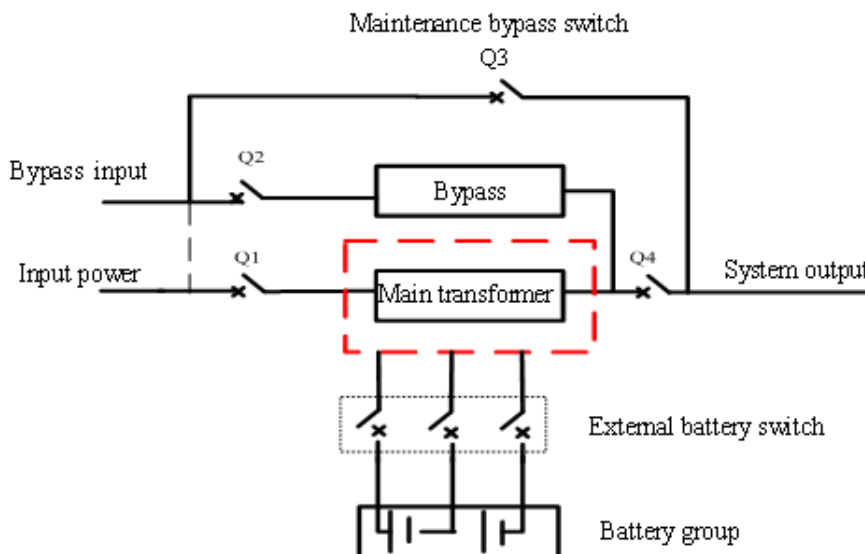

Fig 3-1 System principle framework

3.1.2 Bypass Module

The circuit blocks labeled “bypass module” in fig 3-1 contain electronically controlled switching circuits that enable the critical load to be connected to either the inverter output or to a bypass power source via the static bypass line. During normal system operation the load is connected to the inverter; but in the event of a UPS overload or inverter failure, the load is automatically transferred to the static bypass line.

To provide a clean (no-break) load transfer between the inverter output and static bypass line, the inverter output and bypass supply must be fully synchronized during normal operating conditions. This is achieved through the inverter control electronics, which makes the inverter frequency track that of the static bypass supply, provided that the bypass remains within an acceptable frequency window.

A manually controlled maintenance bypass supply is incorporated into the UPS design. It enables the critical load to be powered from the utility (bypass) supply while the UPS is shut down for routine maintenance.



Note

When the UPS is operating in bypass mode or on maintenance bypass, the connected equipment is not protected from power failures or surges and sags.

3.1.3 Battery Temperature Compensation

The UPS can connect temperature sensor which is in the battery cabinet to the UPS monitor unit through battery temperature interface in order to reach battery management optimization.

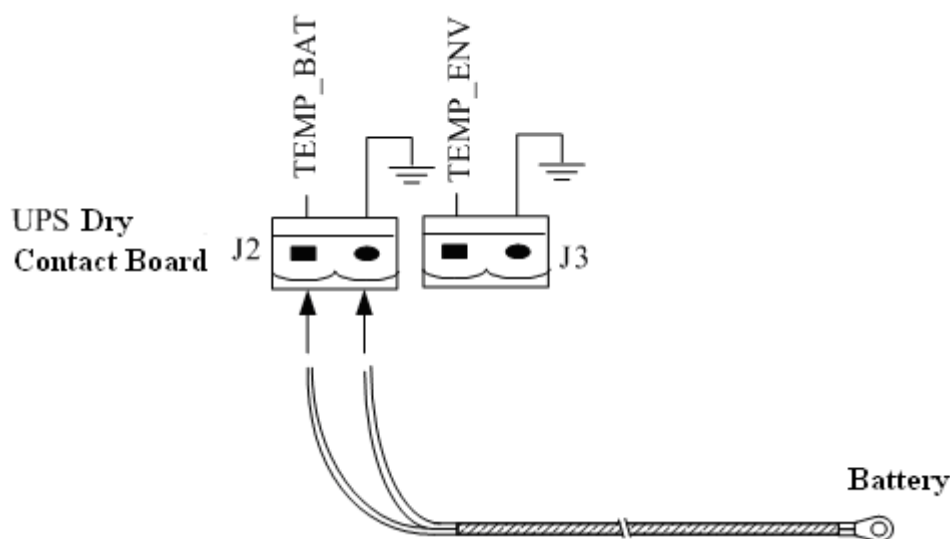

Fig 3-2 Temperature compensation diagram

3.2 Operation Mode

The HT33 UPS is an on-line, double-conversion, reverse-transfer UPS that permits operation in these modes:

- Normal mode
- Battery mode
- Auto-Restart mode
- Bypass mode
- Maintenance mode (manual bypass)
- ECO mode

- Frequency converters mode
- Parallel operation redundancy mode

3.2.1 Normal Mode

The UPS inverter power modules continuously supply the critical AC load. The rectifier/charger derives power from the AC mains input source and supplies DC power to the inverter while simultaneously FLOAT or BOOST charging its associated backup battery.

3.2.2 Battery Mode

Upon failure of the AC mains input power; the inverter power modules, which obtains power from the battery, supplies the critical AC load. There is no interruption in power to the critical load upon failure. After restoration of the AC mains input power, the “Normal Mode” operation will continue automatically without the necessity of user intervention.

Note: UPS can also be started through battery (charged) mode via battery cold start function upon failure of the AC mains. Therefore, the battery power can be used independently to improve the utilization rate of UPS.

3.2.3 Auto-Restart Mode

The battery may become exhausted following an extended AC mains failure. The inverter shuts down when the battery reaches the End of Discharge voltage (EOD). The UPS may be programmed to “Auto Recovery after EOD” after a delay time if the AC main recovers. This mode and any delay time are programmed by the commissioning engineer.

During the process of delay time, the battery will be charged by UPS to prevent any risks to load equipment from future mains failure.

3.2.4 Bypass Mode

If the inverter overload capacity is exceeded under normal mode, or if the inverter becomes unavailable for any reason, the static transfer switch will perform a transfer of the load from the inverter to the bypass source, with no interruption in power to the critical AC load.

3.2.5 Maintenance Mode

A manual bypass switch is available to ensure continuity of supply to the critical load when the UPS becomes unavailable e.g. during a maintenance procedure.

It must take care that after UPS system supplies the power with the bypass mode, close the maintenance bypass switch Q3, and then open Q1, Q2, Q4 and battery switches.



Warning: Hazard may occur after transferring to maintenance bypass

After UPS being transferred to maintenance bypass, power module and bypass module do not work with no display on LCD, and input and output terminals as well as N bus are charged.

3.2.6 ECO Mode

If economical (ECO) mode is selected, the double-conversion UPS will stop to work so as to save energy. During the operation of ECO mode, the load power will be supplied by bypass preferentially. When bypass power is within the range of normal frequency and voltage, load power will be supplied by bypass, or the system will transfer to inverter output, followed by load power interruption which extends within 1/2 of the period. E.g. when the frequency is 50Hz, the interruption time will be less than 10ms; when the frequency is 60Hz, the time will be less than 8.2ms.

3.2.7 Frequency Converters Mode

If the frequency converter configuration is used by UPS, it will provide 50Hz or 60Hz stable output frequency. The range of output frequency is 40Hz-70Hz. Under this mode, static bypass is unavailable, but battery can be selected according to the actual requirements of battery mode.

3.2.8 Parallel connection redundancy mode

Several single UPS devices may be parallel connected directly and the parallel operation control logic in single UPS devices ensures all single device automatically average the load to improve the capacity or reliability of the system, or both the capacity and reliability of the system. The capacity of a parallel operation system can be up to 6 units.

3.3 Battery Management

3.3.1 Normal Function

The following functions should be fitted by commissioning engineers with specified software.

1. Constant current boost charging

Current can be set up.

2. Constant voltage boost charging

Voltage of boost charging can be set as required by the type of battery.

For Valve Regulated Lead Acid (VRLA) batteries, maximum boost charge voltage should not exceed 2.4V / cell.

3. Float charge

Voltage of float charging can be set as required by the type of battery.

For VRLA, float charge voltage should be between 2.2V to 2.3V.

4. Float charge temperature compensation (optional)

A coefficient of temperature compensation can be set as required by the type of battery.

5. End of discharge (EOD) protection

If the battery voltage is lower than the EOD, the battery converter will shut down and the battery is isolated to avoid further battery discharge. EOD is adjustable from 1.6V to 1.75V per cell (VRLA) or 0.9 to 1.1 V per cell

6. Battery low warning time

It is adjustable between 3 and 60 minutes. The default is 5 minutes.

3.3.2 Advanced Functions (Battery Self-checking and Maintenance)

At periodic intervals, 20% of the rated capacity of the battery will be discharged automatically, and the actual load must exceed 20% of the rated UPS (KVA) capacity. If the load is less than 20%, auto-discharge cannot be executed. The periodic interval can be set from 30 to 360 days. The battery self-test can be disabled.

Conditions—Battery at float charge for at least 5 hours, load equal to 20~100% of rated UPS capacity

Trigger—Manually through the command of “Battery Maintenance Test” in LCD panel or automatically

3.4 Battery Protection

The following functions should be fitted by commissioning engineers with specified software.

1. Battery Low Pre-warning

The battery undervoltage pre-warning occurs before the end of discharge. After this pre-warning, the battery should have the capacity for 3 remaining minutes discharging with full load. The time is user configured from 3 to 60 minutes.

2. Battery discharge (EOD)off protection

If the battery voltage is lower than the EOD, the battery converter will be shut down. EOD is adjustable from 1.6V to 1.75V per cell (VRLA) or 0.9 to 1.1 V per cell (NiCd)

3. Battery Circuit Breaker (BCB) Alarm (Optional)

The alarm occurs when the battery disconnect device disconnects. The external battery connects to the UPS through the external battery circuit breaker. The circuit breaker is manually closed and tripped by the UPS control circuit.

Chapter 4 Installation of Parallel Operation System

The parallel operation system is installed as required by the installation procedures of the single system and this chapter.

The single devices are put parallel and connected as shown in fig. 4-1, and the difference between the lengths of the output cables of the single devices is not more than 10m. It is recommended to use an external bypass cabinet to facilitate maintenance and system testing.

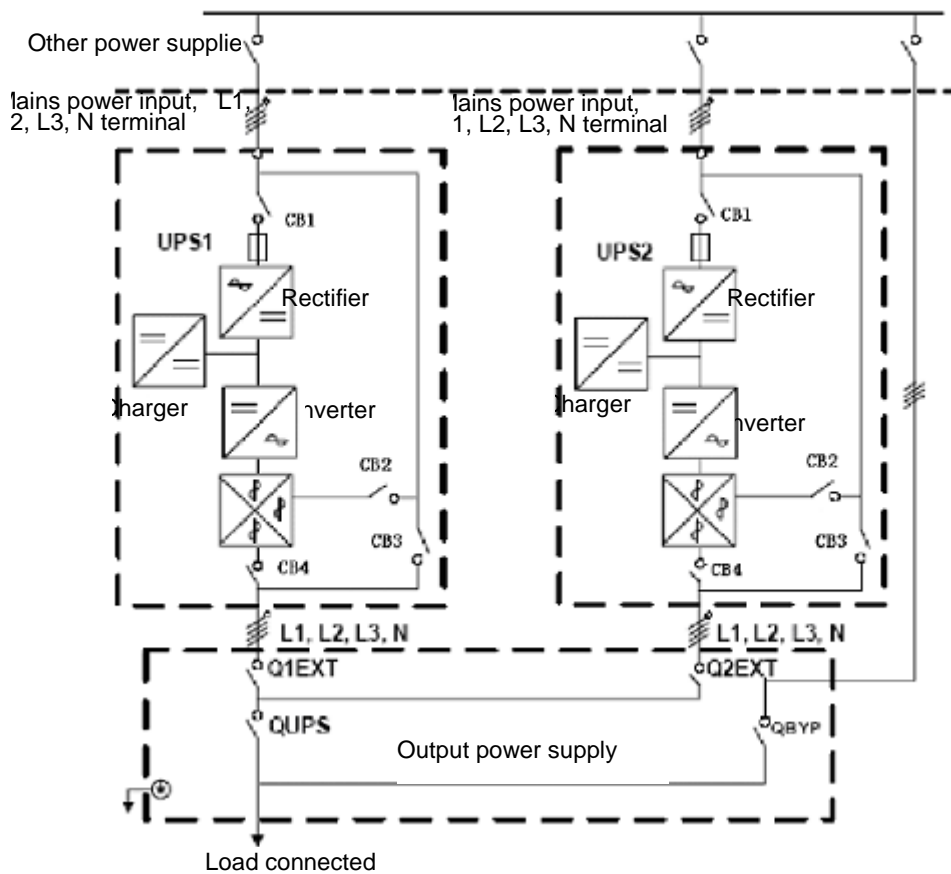

Fig. 4-1 Typical 1+N parallel operation system

Note: when the load exceeds is the capacity of the single device, the maintenance bypass switch CB3 must be removed.

The cables for the parallel operation provide double insulation shielding up to 30m long, the control cables for the parallel operation must be connected with all single devices to form a closed loop, as shown in fig.4-2.

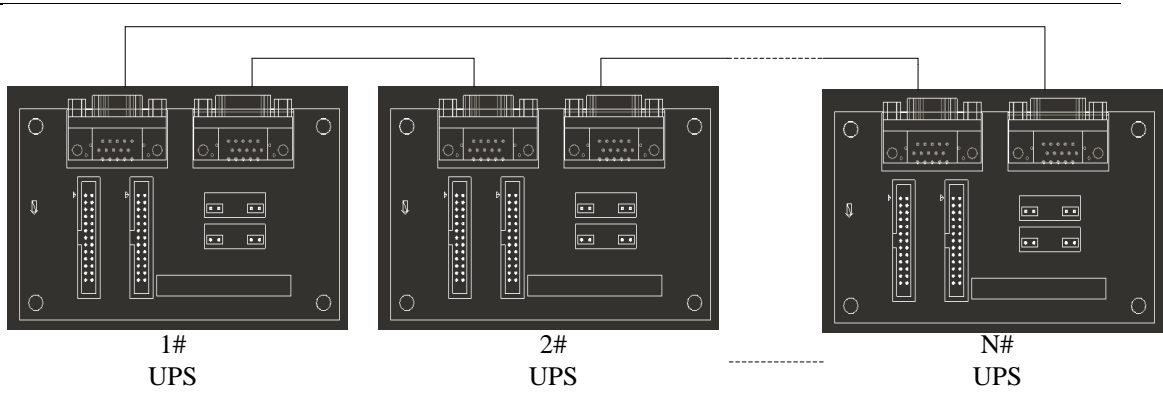

Fig.4-2 parallel cables

Chapter 5 Operating Procedures

This chapter describes UPS operation instructions in detail.

All functional keys and LED display involved in operation instructions please refer to chapter 5. During operation, the buzzer alarm may occur at any time. Select “mute” on LCD to muffle the audible alarm.



Warning-Hazardous mains voltage and/or battery voltage present(s) behind the protective cover

1. The components that can only be accessed by opening the protective cover with tools cannot be operated by user.
2. Only qualified service personnel are authorized to remove such covers.

5.1 Power Switches

As shown in fig 5-1, open the front door of UPS, the power switch is visible, which includes: input switch, output switch and maintenance bypass switch (with anti-misoperation stop plate).

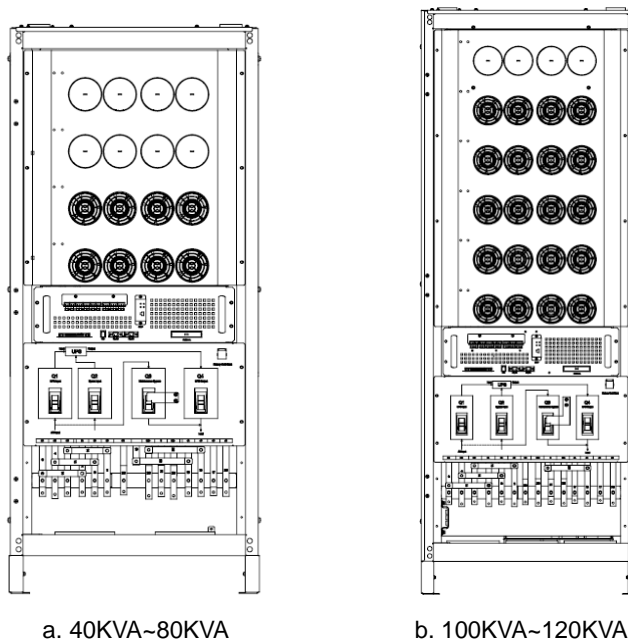

Fig. 5-1 Mains switch location drawing

5.2 UPS Start-up

The UPS system only has a maintenance bypass isolating switch, and all the other transfers are processed automatically by internal control logics.

5.2.1 Normal Mode Start

This procedure must be followed when turning on the UPS from a fully powered down condition. The operating procedures are as follows:



Warning

This procedure results in mains voltage being applied to the UPS output terminals. If any load equipment is connected to the UPS output terminals please check with the load user that it is safe to apply power. If the load is not ready to receive power then ensure that the output switch of external distribution cabinet is opened.



Warning

Please confirm that UPS output rotating switch point to UPS, preventing mistake baffle for rotating switch is fixed well.

1. Close UPS bypass input switch and input switch in turns

The LCD starts up at this time. The Rectifier indicator flashes during the startup of rectifier. The rectifier enters normal operation state, and after about 30s, the rectifier indicator goes steady green. After initialization, the bypass static switch closes. The UPS Mimic LEDs will indicate as shown in table 5-1:

Table 5-1 Indicator status

LED	Status
Rectifier indicator	Green
Battery indicator	Red
Bypass indicator	Green
Inverter indicator	Off
Load indicator	Green
Status indicator	Green

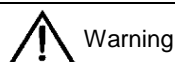

Warning

The bypass input air switch must be opened firstly and then the input air switch is opened, otherwise, the rectifier can not be started and the system can not control the power.

The inverter starts up at this time, the inverter indicator flashes. After the rectifier enters normal operation state, UPS power supply will transfer from bypass to inverter, then the bypass indicator turns off, and load indicator lights. The status of indicators is shown in table 5-2

Table 5-2 Indicator Status

LED	Status
Rectifier indicator	Green
Battery indicator	Red
Bypass indicator	Off
Inverter indicator	Green
Load indicator	Green
Status indicator	Green

If your UPS is with build-in battery type, please close internal battery DC switch. Battery indicator turns off, a few minutes later, the battery will be charged by UPS which will enter normal mode operation. The indicator status is shown in table 5-3.

If your UPS is without build-in battery type, please close external battery DC switch.

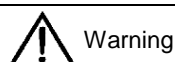

Warning

Please confirm battery connection right before closing external battery switch.

Table 5-3 Indicator status

LED	Status
Rectifier indicator	Green
Battery indicator	Green
Bypass indicator	Off
Inverter indicator	Green
Load indicator	Green
Load indicator	Green

5.2.2 Battery Module Start (Only Applicable for UPS with Battery Cold Start Elements)

1. Check if the batteries have been connected, close the external battery switch.
 2. Press the red start-up button of battery on the back door panel.
3. The LCD starts up at this time, press battery cold start again for about 5 seconds. The green battery indicator flashes. The rectifier enters normal operation states and after about 30s, the battery indicator goes steady green.
4. The inverter starts up automatically, the green inverter indicator flashes. The inverter will output after 60s. Then UPS run in battery mode.

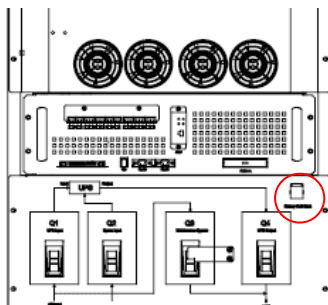

Fig. 5-2 diagrammatic drawing for battery starting button location

5.3 Procedure for Switching between Operation Modes

5.3.1 Procedure for Switching the UPS into Battery from Normal Mode

Open input switch to cut off the mains, UPS enters the battery mode. If UPS should be switched to normal mode, wait for a few seconds before closing input switch, so as to supply the mains again. 10s later, the rectifier will start up automatically to supply power to the inverter.

5.3.2 Procedure for Switching the UPS into Bypass from Normal Mode

1. Click icon in homepage as below:

2. Input password:

3. Click "Tran Byp":

4. Click confirm button:

5. Then you will see the display as below:

The inverter indicator and status indicator go off, the buzzer alarms. The load will be transferred to static bypass, and the inverter is closed.



Note

In bypass mode, the load is directly fed by the mains power instead of the pure AC power from the inverter.

5.3.3 Procedure for Switching the UPS into Normal from Bypass Mode

Select “Esc Byp” on the LCD, about 3 seconds later, UPS transfer to inverter mode automatically.

5.3.4 Procedure for Switching the UPS into a Maintenance Bypass from Normal Mode

In normal operation, this operation instruction will switch the load from inverted input to maintenance bypass.



Caution

Before making this operation, read messages on display to be sure that bypass supply is regular and the inverter is synchronous with it, so as not to risk a short interruption in powering the load.

1. Switch UPS from normal mode to bypass mode according to “5.3.2”;
2. The maintenance bypass switch Q3 is closed or the rotary air switch is switched to the maintenance bypass in order that the load power supply is supplied by the maintenance bypass, and the mains switch Q1, the bypass switch Q2, the output switch Q4 and external battery switches are disconnected.



Warning

If it is required to maintain the modules, the cabinet is opened for internal maintenance after waiting for 10 minutes in order that the capacitor voltage in the internal DC bus automatically discharges.

5.3.5 Procedure for Switching the UPS into Normal from a Maintenance Bypass Mode

This procedure can transfer the load to normal main mode when the UPS is operating under the maintenance bypass mode.

1. Close the bypass switch Q2 and output switch Q4.
The indicator light of the bypass become green and the power is supplied for the load by the bypass and maintenance bypass.
2. Open the maintenance bypass switch Q3.
The power is supplied for the load by the bypass. At the same time, the rectifier begins to operate,

the indicator light of the rectifier become green after 30 seconds, and the power is automatically supplied with the inverter after 2 minutes.

3. Close external battery switch. If the indicator light of the battery does not work, please confirm the voltage of the LCD display battery is normal.
4. Replace the preventing mistake baffle for rotary switch.

5.4 Procedure for Completely Powering down a UPS

If you need to power down the UPS completely, follow the procedures in section 5.3.4 to transfer the UPS from normal mode to maintenance bypass mode.

If you need to isolate the UPS from the AC power supply, you should open the external input switch.

5.5 EPO Procedure

The EPO button on UPS operator control and display panel is designed to switch off the UPS in emergency conditions (e.g., fire, flood, etc.). To achieve this, just press the EPO button, and the system will turn off the rectifier, inverter and stop powering the load immediately (including the inverter and bypass output), and the battery stops charging or discharging.

If the input utility is present, the UPS control circuit will remain active; however, the output will be turned off. To completely isolate the UPS, you need to disconnect the external mains input supply to the UPS.

5.6 Language Selection

The LCD is available in three languages: Chinese, English and a kind of optional language (Traditional Chinese, Korean, Turkish and Russian).

The language can be selected through LCD prompt window.

5.7 Control Password

When the LCD displays "input control password 1", the initial password is 12345678.

Chapter 6 Operator Control and Display Panel

This chapter introduces the functions and operation instructions of the parts on UPS operator control and display panel in detail, and provides LCD display information, including LCD display types, detailed menu information, prompt window information and UPS alarm list.

6.1 Introduction

The operator control and display panel is located on the front panel of the UPS. Through this LCD panel, the operator can operate and control the UPS, and check all measured parameters, UPS and battery status and event and alarm logs. The operator control panel is divided into three functional areas as shown in fig 6-1: mimic current path, LCD display & Menu keys, and Control and Operation Keys.



Fig 6-1 UPS operator control and display panel

Table 6-1 Description of UPS operator control and display panel

Part No.	Function	Button (40KVA~120KVA)	Function
REC	Rectifier indicator	EPO	EPO switch
BAT	Battery indicator	TAB	Back to main menu
BYP	Bypass indicator	ENTER	Confirm
INV	Inverter indicator	ESC	Escape
OUTPUT	Load indicator		
STATUS	Status indicator		

6.1.1 LED Indicator

The LEDs shown on the mini current path represent the various UPS power paths and show the current UPS operating status. The status description of indicators is shown in table 6-2.

Table 6-2 Status description of indicator

Indicator	State	Purpose
Rectifier indicator	Steady green	Rectifier normal
	Flashing green	Rectifier starting, mains normal
	Steady red	Rectifier fault
	Flashing red	Mains abnormal
	Off	Rectifier not operating
Battery indicator	Steady green	Battery charging
	Flashing green	Battery discharging
	Steady red	Battery abnormal (battery failure, no battery or battery reverse) or battery converter abnormal (failure, overcurrent or over temperature) , EOD
	Flashing red	Battery low voltage
	Off	Battery and battery converter normal, battery not charging
Bypass indicator	Steady green	Load power supplied by bypass
	Steady red	Bypass power abnormal or out of normal range, or static bypass switch fault
	Flashing red	Bypass voltage abnormal
	Off	Bypass normal
Inverter indicator	Steady green	Load power supplied by inverter
	Flashing green	Inverter On, start, synchronization of standby (ECO mode)
	Steady red	System power not supplied by inverter, inverter fault
	Flashing red	System power supplied by inverter, inverter fault
	Off	Inverter not operating
Load indicator	Steady green	UPS output ON and normal
	Steady red	UPS output overload and overtime, or output short, or output no power supply
	Flashing red	Overload output of UPS
	Off	No output of UPS
Status indicator	Steady green	Normal operation
	Steady red	Failure

6.1.2 Audible Alarm (buzzer)

There are two different types of audible alarm during UPS operation as shown in table 6-3.

Table 6-3 Description of audible alarm

Alarm	Purpose
Two short alarm with one long alarm	when system has general alarm (for example: AC fault), this audible alarm can be heard
Continuous alarm	When system has serious faults (for example: fuse or hardware fault), this audible alarm can be heard

6.1.3 Functional Keys

There are 4 functional keys on operator control and display panel, which are used together with LCD. The functions description is shown in table 6-4

Table 6-4 Functions of functional key

Functional key	Functions
EPO switch	To cut off the load power to shut down the rectifier, inverter, static bypass and battery
TAB	switch
ENTER	confirm
ESC	exit

6.2 LCD Display Type

After UPS starting screen completes self-inspection, main display shown in fig. 6-2 appears. The main panel display for 40KVA~120KVA type is provided with three display windows: a system information window, a data and instruction window, and a current record window.

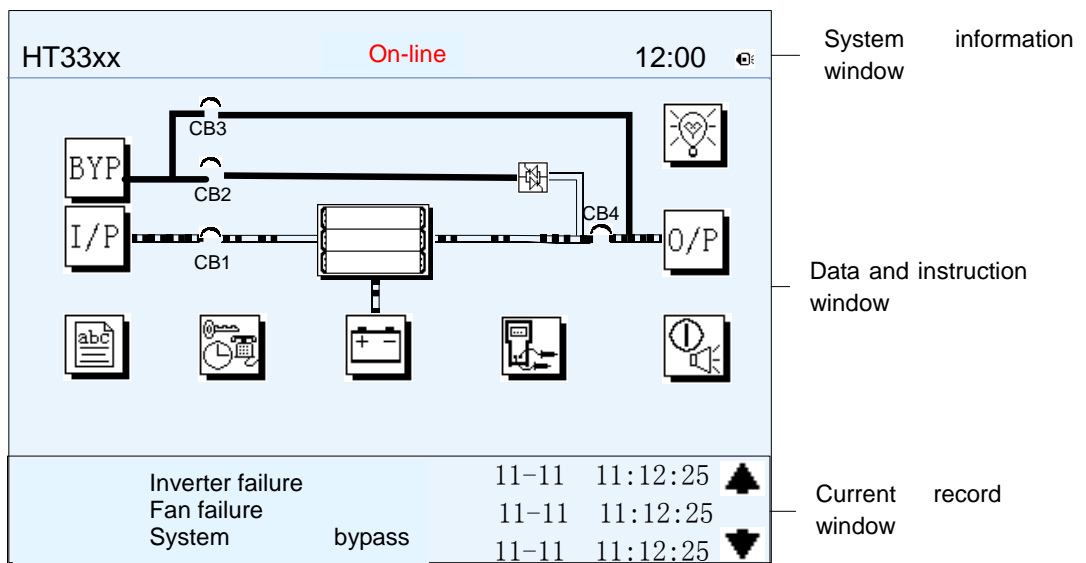
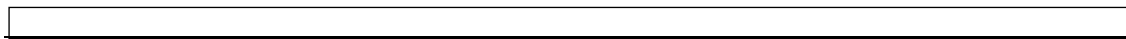

Fig. 6-2 Homepage display

Decryption of LC icons (applicable for the panel of 40KVA~120KVA type)

Icon	Description
	Bypass parameter
	Main input parameter
	History file, system information
	Function setting (display calibration, password setting, time setting, date format, communication protocol and language setting), system setting (used by product maintainers)
	Battery data, battery parameter setting (used by service staff)
	Test (battery self-test, battery maintenance)



Icon	Description
	Functional keys used by service staff (fault clearing, history file clearing, noise clearing, manual switch of bypass), user's setting (system mode, machine number, system ID, output voltage adjustment, frequency tracing speed, frequency tracing limit)
	Output parameter
	Load
	Noise clearing, noise clearing cancel
	Log view page up/down





Select an icon on LCD, to view the UPS parameter represented by this icon, e.g. select , the LCD will display the data of system main input:

HT33		on-line		12:00	
V phase		I phase		Main input	
A	219.5	A	18.3		
B	219.5	B	18.3		
C	219.5	C	18.3		
Frequency		Power factor			
A	50.01	A	0.99		
B	50.01	B	0.99		
C	50.01	C	0.99		

Fig. 6-3 Select Data

Select  in the operating status to view the main input data.

Select  in the operating status to view the main output data.

Select , in the operating status to view the load data.

Select  in the operating status to view the MAINT code and software code.

Select  to return to the previous page

Select  to return to the home page

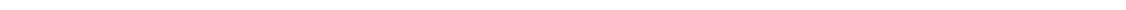

6.2.1 Default Display

During the operation of system, if there's no alarm in 2 min, the system will display default. After a short delay, the backlight of LCD display goes off; press any key to reactivate the display.

6.2.2 System information window

UPS information window: display the current time and UPS name. The information of the window is not necessary for the user to operate. The information of this window is given in table 6-5.

Table 6-5 Description of items in UPS system information window

Display contents	Meaning
HT33-XXX	UPS Name
12:00	Current Time (format: 24 hours, hours, minute)

6.2.3 UPS menu and data window

UPS menu window displays the menu name of data window, while the data window displays the related contents of selected menu in menu window. Select UPS menu and data window to browse related parameters of UPS and set related functions. The details are given in table 6-6

Table 6-6 Item description of UPS menu and data window

Menu name	Menu item	Meaning
Main input	V phase(V)	Phase voltage
	I phase(A)	Phase current
	Freq.(Hz)	Input frequency
	PF	Power factor
Bypass input	V phase(V)	Phase voltage
	Freq. (Hz)	Bypass frequency
	I phase(A)	Phase current
	PF	Power factor
AC output	V phase(V)	Phase voltage
	I phase(A)	Phase current
	Freq. (Hz)	Output frequency
	PF	Power factor
UPS load	Sout (kVA)	Sout: Apparent Power
	Pout (kW)	Pout: Active Power
	Qout (kVAR)	Qout: Reactive Power
	Load (%)	Load (The percentage of the UPS rating load)
Battery data	Environmental Temp	Environmental Temp
	Battery voltage(V)	Battery bus voltage
	Battery current A)	Battery bus current
	Battery Temp(°C)	Battery Temp °C
	Remaining Time (Min.)	Remaining battery backup time
	Battery capacity (%)	The percentage compared with new battery capacity
	battery equalized charging	Battery is equalized charging
	battery float charging	Battery is float charging
Battery disconnected	Battery is not connected	
Current record	(current alarm)	Display all current alarm. The alarm list displayed on LCD of UPS operator control and display panel please refer to table 6-7

Menu name	Menu item	Meaning
History record	(history alarm)	Display all history alarm. The alarm list displayed on LCD of UPS operator control and display panel please refer to table 6-7
Menu Language	(language option)	3 languages can be selected
Settings	Display calibration	Adjust the accuracy of LCD display
	Date format set	MM DD YYYY and YYYY MM DD formats can be selected
	Date & Time	Date/Time set
	Language set	User can set the language
	Communication mode	Set communication mode, MODBUS, Power protocol and company custom protocol modes can be selected. Power protocol mode can be divided into equipment address, baud rate set; MODBUS protocol mode can be divided into communication, mode (RTU、ASC II), equipment address, baud rate and check-bit set; Company custom protocol mode is the customized protocol of the company, no option is available.
Control password set	User can modify control password 1	
Test Command (Battery Test Control / System Test Control / Forced equalized charging)	Battery maintenance test	this test will lead to the battery being partly discharged to activate battery, at the same time; the approximate battery capacity will be obtained. Bypass must be in normal condition, the battery capacity should be above 25%.
	Battery self-check test	UPS switches to battery discharge for discharging to test if the battery is normal. Bypass must be in normal condition, the battery capacity should be above 25%.
	Stop testing	Manually Stop the test including maintenance test, capacity test
System information	Monitoring software version	Provide monitoring software version
	Rectified software version	Provide rectified software version
	Inverted software version	Provide inverted software version
	Serial No.	The serial no. set when delivery from the factory
	Rated information	Network setting of system operating

6.3 Alarm List

The follow table 6-7 gives the complete list of all the UPS events displayed by history record window and current record window.

Table 6-7 Alarm List

Alarm	Explanation
UPS power supply	The system is in normal inverted power supply status
Bypass power supply	The system is in bypass power supply status
No power supply	System no output
Battery equalized charging	Battery is in boost charging
Battery float charging	Battery is in float charging
Battery discharging	The system is operating in battery discharging status.
Battery connected	Battery is connected

--

Battery disconnected	Battery is not connected
Maintenance circuit breaker close	Maintenance circuit breaker is close
Maintenance circuit breaker open	Maintenance circuit breaker is open
Emergency shutdown	System emergency shutdown, EPO
Generator connected	External generator is connected
Mains abnormal	Input mains abnormal
Bypass phase conversion	Bypass input phase converse
Bypass voltage abnormal	Bypass input voltage abnormal
Bypass fault	Bypass fault
Bypass overload	Bypass output is overload
Up to bypass overtime of overload	Bypass is overtime of overload
Bypass frequency tracing exceeds	Bypass frequency is out of the tracing range
Switch times up to in this hour	The times of switch between bypass and inverter exceeds 5 times in the latest hour.
Output short	System output short
Battery EOD	Battery voltage achieves shutdown point
Battery self-check	The system enters battery self-check mode
Battery self-check success	Battery normal during system self-check
Battery manual check failure	Battery fault during system self-check
Battery maintenance	The system is in battery maintenance status
Battery maintenance success	Battery maintenance status completes
Battery maintenance failure	Battery maintenance process is not normal
Stop testing	Battery self-check or battery maintenance status stops
Fault clearing	Clear the alarmed fault
Delete history record	Delete all history record
Inverter power supply ban	Inverter power ban supply
Manual switch of bypass	Switch the system to bypass output manually
Cancel manual switch of bypass	Switch the system from bypass to inverter output manually
Battery low voltage	Battery low voltage
Battery reversal	Battery polarity reversal
Input N line disconnected	System input N line is not connected
Bypass fan fault	Bypass module fan fault
ManualShutdown	Shut down UPS by manual

Note: if the alarm is caused by the set value of the software, the modification of set value should contact the local service center.

Chapter 7 Maintenance

This chapter introduces UPS maintenance, including the maintenance instructions of power module, monitoring bypass module and the change method of dust filter.

7.1 Instruction of Maintenance Operation

7.1.1 Precautions

1. Only maintaining engineers can do this job.
 2. In principle, the broken elements should be disassembled from top to bottom, so as to prevent any inclination from high gravity centre of the cabinet.
 3. To ensure the safety before maintaining power module and bypass module, be sure to use a multimeter to measure the DC bus capacitor voltage and ensure the voltage is below 60V before operation, and use a multimeter to measure the voltage between operating parts and the earth to ensure the voltage is lower than hazardous voltage, i.e. DC voltage is lower than 60Vdc, and AC maximum Voltage is lower than 42.4Vac.
 4. Only after 10 minutes removing the power components and bypass components, the maintenance can be carried out.

7.1.2 Instruction to Bypass Module

Suppose UPS were in normal mode, and the bypass were normal:

1. Select manual switch of bypass in LCD screen, the UPS power will be supplied by bypass.
2. Close maintenance bypass switch, the UPS power will be supplied by maintenance bypass.
3. Open UPS output switch and input switch.
4. Open external battery switch battery switch.
5. Take the door sheet of UPS off, remove and repair the damage components,
6. Reinstall the corresponding components in the cabinet after maintenance, reinstall the internal door sheet, and complete connection of the flat cables at the front of the internal door.
7. Close output switch and input switch in turns.

After 5 seconds, the indicator light of the operating control display panel works, which shows the power is normally supply by the bypass.
8. Open maintenance bypass switch, the inverter automatically starts, and UPS operates in the normal mode after 60 seconds.
9. Close external battery switch, the battery light on the panel turns off, which show connection with the battery; inspect the battery voltage is normal or not which is shown on the panel.
10. Replace the preventing mistake baffle of maintenance bypass.

7.2 Replacement of dust screen (optional)

As shown in fig 7-1, there are 3~4 dust filters on the back of UPS' front door, each screen is held in

place by a bracket on either side of each filter. The procedure of replacing each filter is as follows:

1. Open the UPS' front door and locate the filters on the back side of the front door
2. Remove one bracket
3. Remove the dust screen to be replaced and insert the clean one
4. Reinstall the bracket

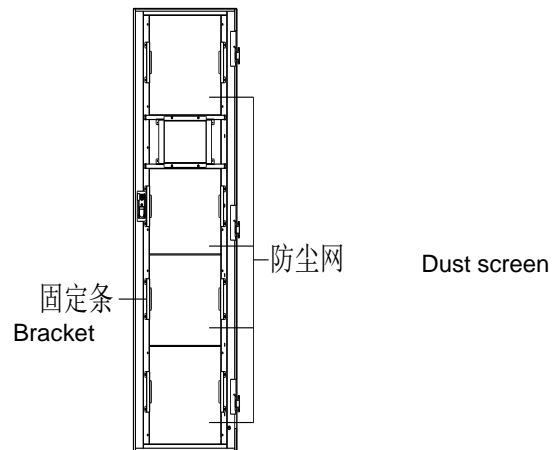

Fig 7-1 Dust screen on the back side of UPS' front door

Chapter 8 Product Specification

This chapter describes the product specification of UPS

8.1 Applicable Standards

UPS design meets the European and national standards given in Table 8-1.

Table 8-1 Compliance with European and International Standards

Item	Normative reference
General Safety Requirements for UPS Used in Operator Access Areas	EN50091-1-1/IEC62040-1-1/AS 62040-1:2009
Electromagnetic Compatibility (EMC) Requirements for UPS	EN50091-2/IEC62040-2/AS 62040-2
Method of Specifying the Performance and Test Requirements of UPS	EN50091-3/IEC62040-3/AS 62040-3(VFI SS 111)
Note: The above mentioned product standards incorporate relevant compliance clauses with generic IEC and EN standards for safety (IEC/EN/AS60950), electromagnetic emission and immunity (IEC/EN/ AS61000 series) and construction (IEC/EN/AS60146 series and 60950)	

8.2 Environmental Characteristics

Table 8-2 Environmental Properties

Items	Unit	Requirements
Acoustic noise level at 1 meter	dB	55.0
Altitude of Operation	m	≤1000m above sea level, derate power by 1% per 100m between 1000m and 2000m
Relative Humidity	%RH	0 to 95% non condensing
Operating Temperature	°C	0 to 40 deg , Battery life is halved for every 10°C increase above 20°C
UPS Storage-Transport Temperature	°C	-20-70
Recommended Battery Storage Temperature	°C	-20-30 (20°C for optimum battery storage)

8.3 Mechanical Characteristics

Table 8-3 Mechanical Properties

Items	Unit	HT33040	HT33050	HT33060	HT33080	HT33100	HT33120
Mechanical Dimension, W×D×H	mm	600*900*1400				600*900*1700	
Weight	kg	182	204	204	226	270	292
Color	N/A	Black					
Protection Level, IEC(60529)	N/A	IP20					

8.4 Electrical Characteristics (Input Rectifier)

Table 8-4 Rectifier AC input (mains)

Items	Unit	Parameter
Rated AC Input Voltage	Vac	380/400/415(three-phase and sharing neutral with the bypass input)
Input Voltage Range	Vac	-40%+25%
Frequency	Hz	50/60(range: 40Hz-70Hz)
Power Factor	kW/kVA, full load	0.99
THD	THDI%	3

8.5 Electrical Characteristics (Intermediate DC Link)

Table 8-5 Battery

Items	Unit	Parameters
Battery Bus Voltage	Vdc	Nominal: $\pm 240V$, one-side range: 198V-288V
Quantity of Lead-acid cells	standarization	40=[1 battery(12V)] , 240=[1 battery(2V)]
Float Charge Voltage	V/cell(VRLA)	2.25V/cell(selectable from 2.2V/cell-2.35V/cell) Constant current and constant voltage charge mode
Temperature Compensation	mV/°C/cell	-3.0(selectable from : 0-5.0, 25°C or 30°C, or inhibit)
Ripple Voltage	% V float	≤ 1
Ripple Current	% C ₁₀	≤ 5
Boost Charge Voltage	VRLA	2.4V/cell(selectable from : 2.30V/cell-2.45V/cell) Constant current and constant voltage charge mode
EOD Voltage	V/cell(VRLA)	1.65V/cell(selectable from : 1.60V/cell-1.750V/cell) @0.6C discharge current 1.75V/cell (selectable from : 1.65V/cell-1.8V/cell) @0.15C discharge current (EOD voltage changes linearly within the set range according to discharge current)
Battery Charge	V/cell	2.4V/cell(selectable from : 2.3V/cell-2.45V/cell) Constant current and constant voltage charge mode
Battery Charging Power Max Current	kW	10%* UPS capacity (selectable from : 0-20%* UPS capacity)

8.6 Electrical Characteristics (Inverter Output)

Table 8-6 Inverter Output (to important load)

Items	Unit	Parameters
Rated AC Voltage ¹	Vac	380/400/415(three-phase four-wire and sharing neutral with the bypass)
Frequency ²	Hz	50/60
Overload	%	110% load, 1 hour 125% load, 10min 150% load, 1min >150% load, 200ms
Fault Current	%	340% short current limitation for 200ms

Items	Unit	Parameters
Non Linear Load Capability ³	%	100%
Neutral Current Capability	%	170%
Steady State Voltage Stability	%	±1(balanced load) ±1.5(100% imbalance load)
Transient Voltage Response ⁴	%	±5
THD	%	<1(linear load) , <5(non linear load ³)
Synchronization - Window		Rated frequency ±3Hz(selectable: ±1-±5Hz)
Slew rate	Hz/s	1: selectable: 0.5-5
Inverter Voltage Range	%V(ac)	±5

Note:

1. Factory setting is 380V. Commissioning engineers can set to 400V or 415V.
2. Factory setting is 50Hz. Commissioning engineers can set to 60Hz.
3. EN50091-3(1.4.58) crest ratio is 3: 1.
4. IEC62040-3/EN50091-3 including 0%-100%-0% load transient, the recovery time is half circle to within 5% of stable output voltage.

8.7 Electrical Characteristics(Bypass Mains Input)

Table 8-7 Bypass Mains Input

Items	Unit	HT33040	HT33050	HT33060	HT33080	HT33100	HT33120
Rated AC Voltage ¹	Vac	380/400/415 three-phase four-wire, sharing neutral with the rectifier input and providing neutral reference for the output					
Rated Current	A	60@380V 58@400V 56@415V	75@380V 73@400V 70@415V	90@380V 87@400V 83@415V	120@380V 116@400V 112@415V	150@380V 145@400V 140@415V	181@380V 174@400V 168@415V
Overload	%	125% load, long time 130% load, 1 hour 150% load, 6min 1000% load, 100ms					
Superior Protection bypass line	N/A	Thermal-magnetic breaker, the capacity is 125% of rated current output. IEC60947-2 curve C					
Current rating of Neutral Cable	A	1.7×In					
Frequency ²	Hz	50/60					
Switch Time (between bypass and inverter)	ms	Synchronized switch: ≤1ms					
Bypass Voltage Tolerance	%V _a c	Upper limit: +10, +15or+20, default: +20 Lower limit: -10, -20, -30 or-40, default: -20 (acceptable stable bypass voltage delay: 10s)					
Bypass Frequency Tolerance	%	±2.5, ±5, ±10 or ±20, default: ±10					
Synchronization -Window	Hz	Rated frequency±2Hz (selectable from ±0.5Hz-±5Hz)					

Note:

1. Factory setting is 380V. Commissioning engineers can set to 400V or 415V.
2. Factory setting is 50Hz. Commissioning engineers can set to 60Hz. For example, UPS is set to frequency inverter mode, and then bypass status will be neglected.

8.8 Efficiency

Table 8-8 Efficiency, Loss and Air Exchange

Items	Unit	40-120KVA
Efficiency		
Normal mode(dual conversion)	%	95
ECO mode	%	99
Battery discharging efficiency (DC/AC) (battery at nominal voltage 480Vdc and full-rated linear load)		
Battery mode	%	95